

Cessna 172 Passenger Briefing

This document satisfies CAR 602.59

Before passengers are allowed to be carried in an aircraft, a passenger briefing must be performed. ***This is the law.*** It is similar to the ones you see the flight attendants do when you fly in commercial aircraft.

The pilot will go over the passenger briefing with you on the day of the flight. If you have any questions, that would be the time to ask them.

Smoking

There is no smoking in or around the aircraft as well as on the tarmac at any time.

First Aid

There is a first aid kit located behind the rear seat. It is either a white box or a red pouch that says "first aid" on it. Survival equipment will also be located in this area if equipped.

Fire Extinguisher

This airplane is not equipped with a fire extinguisher.

Emergency Locator Transmitter (ELT)

The ELT is a device that helps rescue workers find the aircraft quickly if there is an accident. The ELT is automatically activated and sends GPS co-ordinates to the rescue agency. However, if for some reason the ELT needs to be activated manually you can do so by flipping the switch up to the "on" position.

Only do so if instructed by the pilot. The pilot will show you where the switch is on the day of the flight.

Emergency Exits

There are three possible escape routes from the aircraft. Please use the following order when trying to exit:

1. Side door. To unlock the door, lift the latch up and push the door out.
2. Door Windows. To unlock the window, turn the lock 90 degrees counter-clockwise and open the window.
3. Baggage Compartment. The baggage compartment door is located behind the rear seats on the pilot side of the aircraft. Unlatch the door and push it outwards.

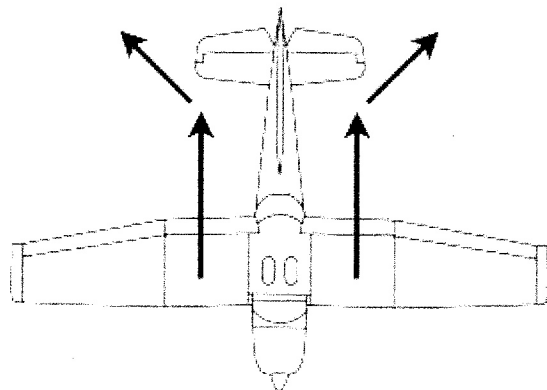
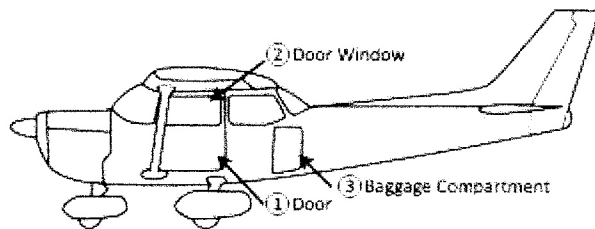

When exiting the aircraft please walk along the tail to the rear and as far away from the plane as possible.

Seat Belts

The seatbelts are standard 3 point style seatbelts similar to those in your car. To unlock the belt: lift up on the buckle and pull the belt out. The pilot will demonstrate how to use the seatbelts on the day of the flight.

Emergencies

In case of an in-flight emergency, the pilot will give you instructions to follow. It is important that you understand these instructions. If you are unsure please ask for clarification immediately.

Comfort

An enjoyable flight is one where you are comfortable. Here are some items to consider when you are going on a flight:

- There are no bathrooms on the airplane, so be sure to take care of business beforehand.
- If you have a pair of sunglasses, bring them.
- Don't forget your camera!
- Wear comfortable clothes. The airplane has heat in the winter to keep warm but there is no air conditioning in the summer time. Please wear closed toe shoes (running shoes are perfect).

During the flight you will be wearing a headset. This headset allows you to talk to other occupants comfortably and reduces noise from the engine. You will also hear radio communication, don't worry they can't hear what you are saying. The pilot may interrupt your conversation in order to listen to important information on the radio.

When you speak into the headset microphone you will be able to hear yourself in the headset. If you cannot, then other occupants cannot hear what you're saying either. Please adjust the microphone boom closer to your mouth or speak louder.